

G20 Engineering
WW/YY PEP21440A01

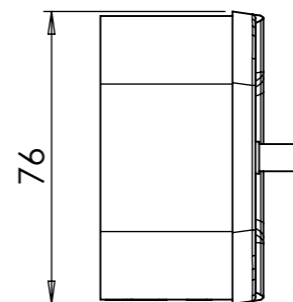
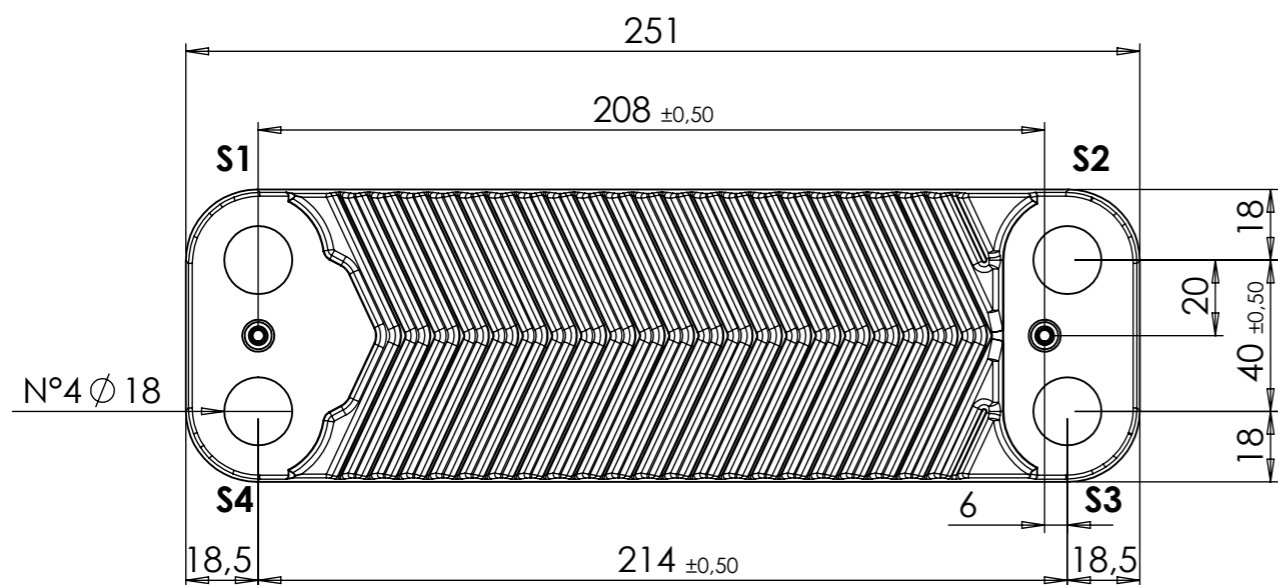
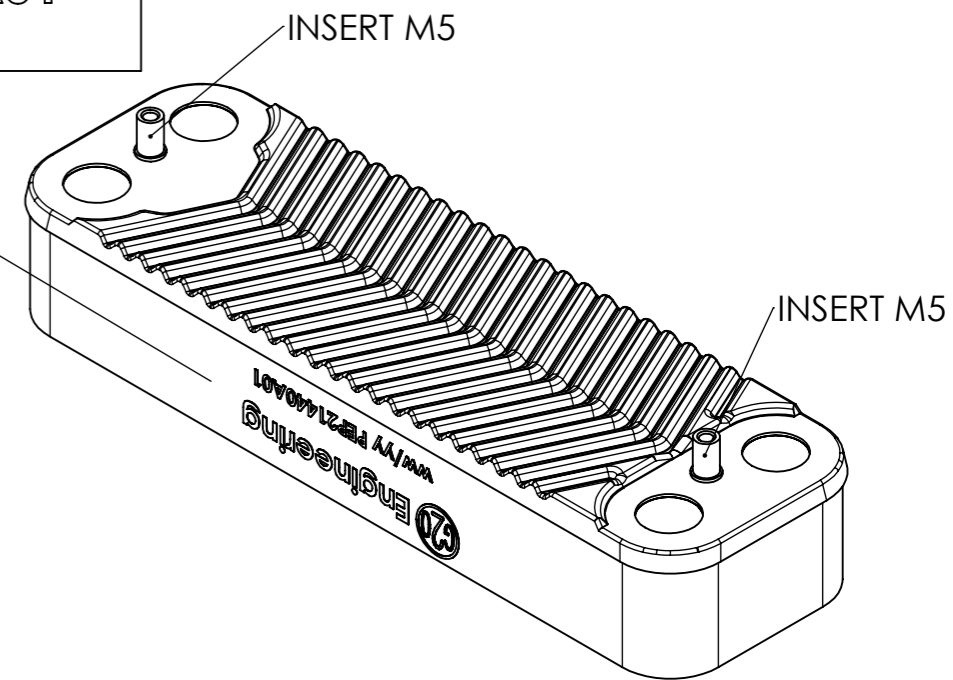

PEP21440A01-22HY	22	-
PEP21440A01-20HY	20	-
PEP21440A01-18HY	18	46 ±2
PEP21440A01-16HY	16	-
PEP21440A01-14HY	14	37 ±2
PEP21440A01-12HY	12	32,5 ±2
PEP21440A01-10HY	10	28 ±2
CODE	PLATE	"A"

S1-S2 PRIMARY SIDE
S3-S4 SECONDARY SIDE

PLATE THICKNESS 0.30 AISI 304L

NOTE : Multy pack

REV.	Date	DESCRIPTION	DRAWN	CHK'D	APPVD
UNLESS OTHERWISE SPECIFIED: DIMENSIONS ARE IN MILLIMETERS SURFACE FINISH: TOLERANCES REFERENCE: ISO 2768-mH		FINISH:	DEBUR AND BREAK SHARP EDGES		DO NOT SCALE DRAWING
					REVISION: 00 del 22/11/19
					G20 Engineering srl
					TITLE: PLATE HEAT EXCHANGER TYPE PEP-21440A01 INOX 304L
					DWG NO. PEP-21440A01-HY
					A3
MATERIAL: AISI 304L		CODE: PEP21440A01-XXHY	WEIGHT:		SCALE:1:2
					SHEET 1 OF 1